

# Technical data KNS300 - 3

# KOALA Series



Q.ty	Components	Code	Base
3	Solar Panel Koala 2.0 Cu Black	KOAMD2VNN	✓
1	Support structure for pitched roofs	STCN303NF	✓
1	Enameled solar boiler with cavity, 300 liters	BV0300ICG	✓
1	Solar safety valve, set point 1.5 bar	IDRVSIC15	✓
1	Drain valve with hose connection	IDRVSCGM1	✓
5	Monopropylene glycol - liters	IDRLQGLCL	✓
<b>Connection kit to the solar boiler</b>			
1	Copper pipe (2.5 meters rod)	IDRTR2522	✓
6	Bent connector 90° 3/4 - 22	IDRRACOTD	✓
	Unions	IDRRACBPP	

### PITCHED ROOF

Mod.	Roof	Solar storage tank	Code
KNS303	Pitched	300	KNS303FBG

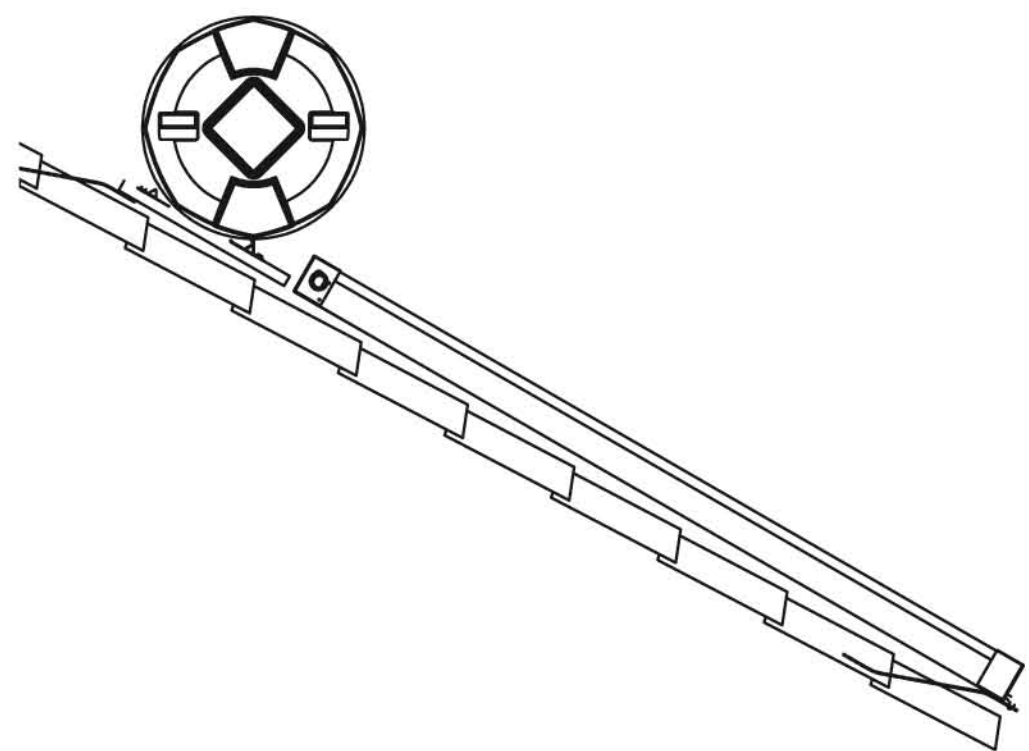
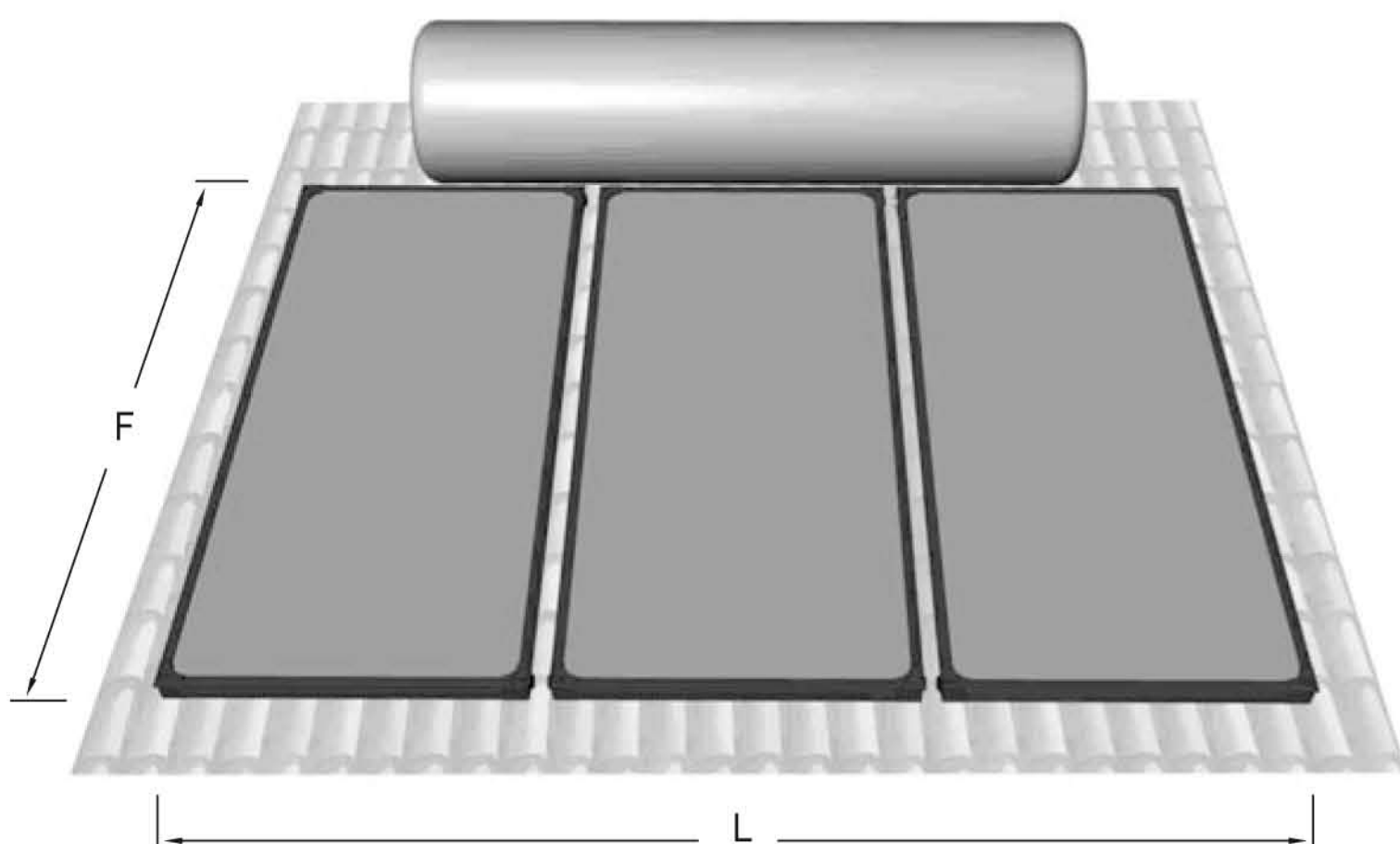

### FLAT ROOF

Mod.	Roof	Solar storage tank	Code
KNS303	30°	300	KNS303EBG

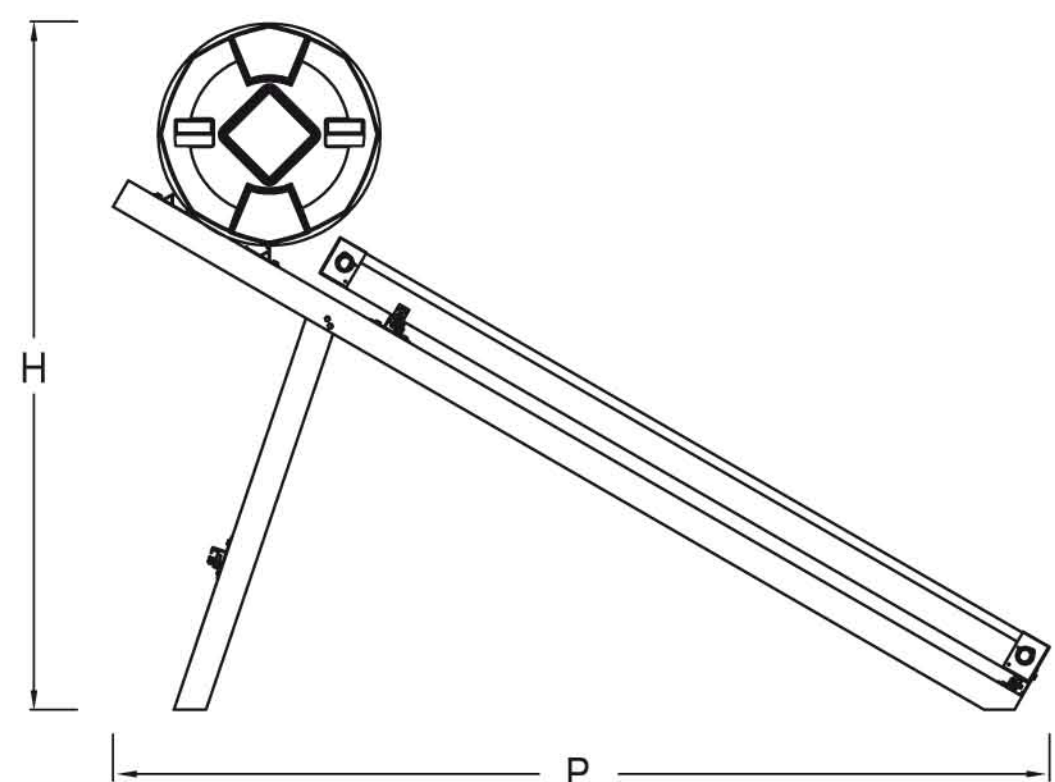
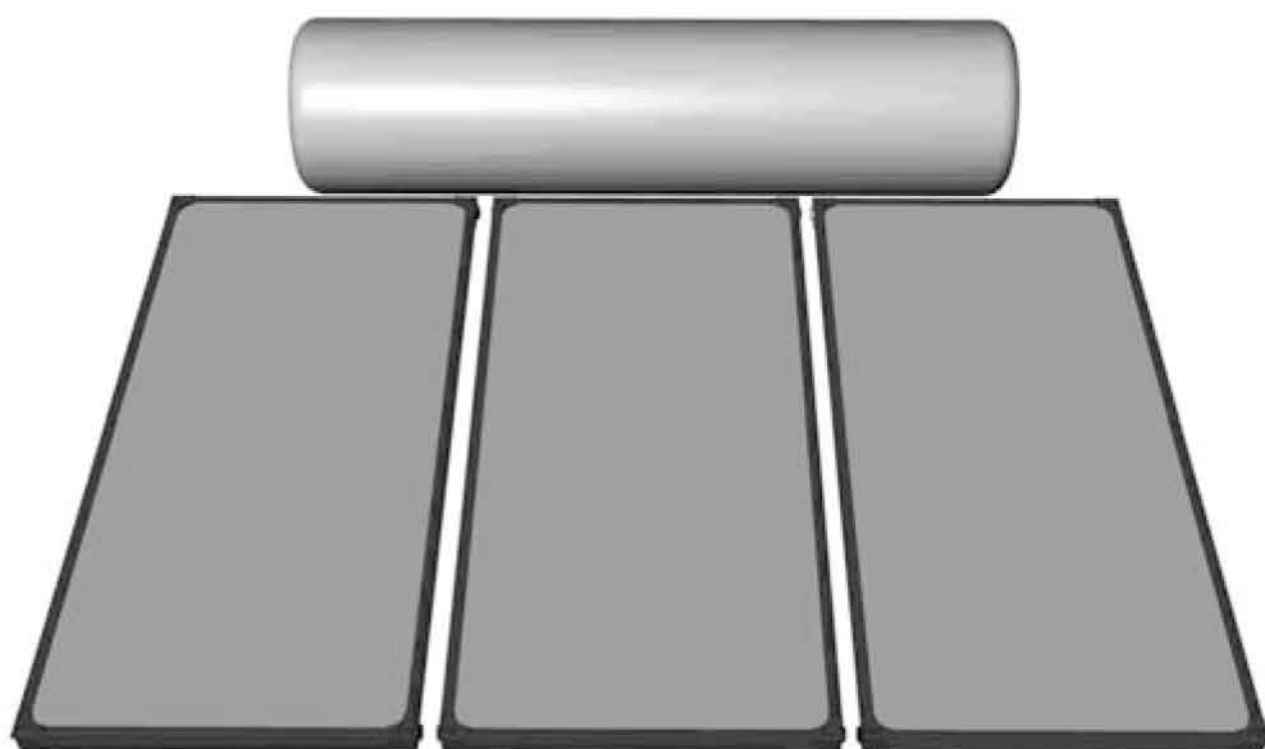

Overall dimensions: **flat roof** LxPxH = 3400x2400x1800 mm empty weight 260 kg  
**pitched roof** LxF = 3400x2800 mm empty weight 245 kg